

*Rossini's Geheime Recept*  
 bovenaanzicht opstelling

Arnold Schalks  
 decorontwerp  
 versie 19 juni 2011  
 schaal 1:20

105  
 PODIUMDEEL I  
 hoogte: 160 cm.

PODIUMDEEL II  
 hoogte: 80 cm.

PODIUMDEEL III  
 hoogte: 40 cm.

PODIUMDEEL IV  
 hoogte: 20 cm.

fauteuil  
 Rossini

480

636

*Rossini's Geheime Recept*  
**PODIUMDEEL I**

overzicht  
 onderbouw en vloer  
 hoogte: 160 cm.  
 plaats voor 2 x hoorn

Arnold Schalks  
 decorontwerp  
 versie 19 juni 2011  
 schaal 1:20

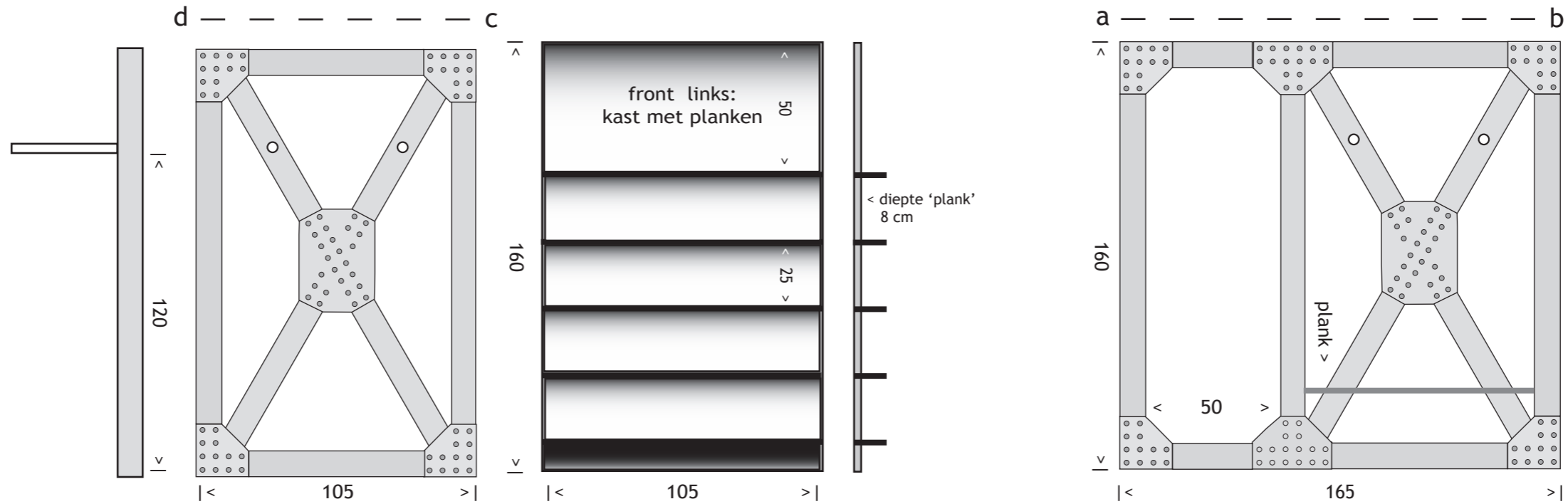
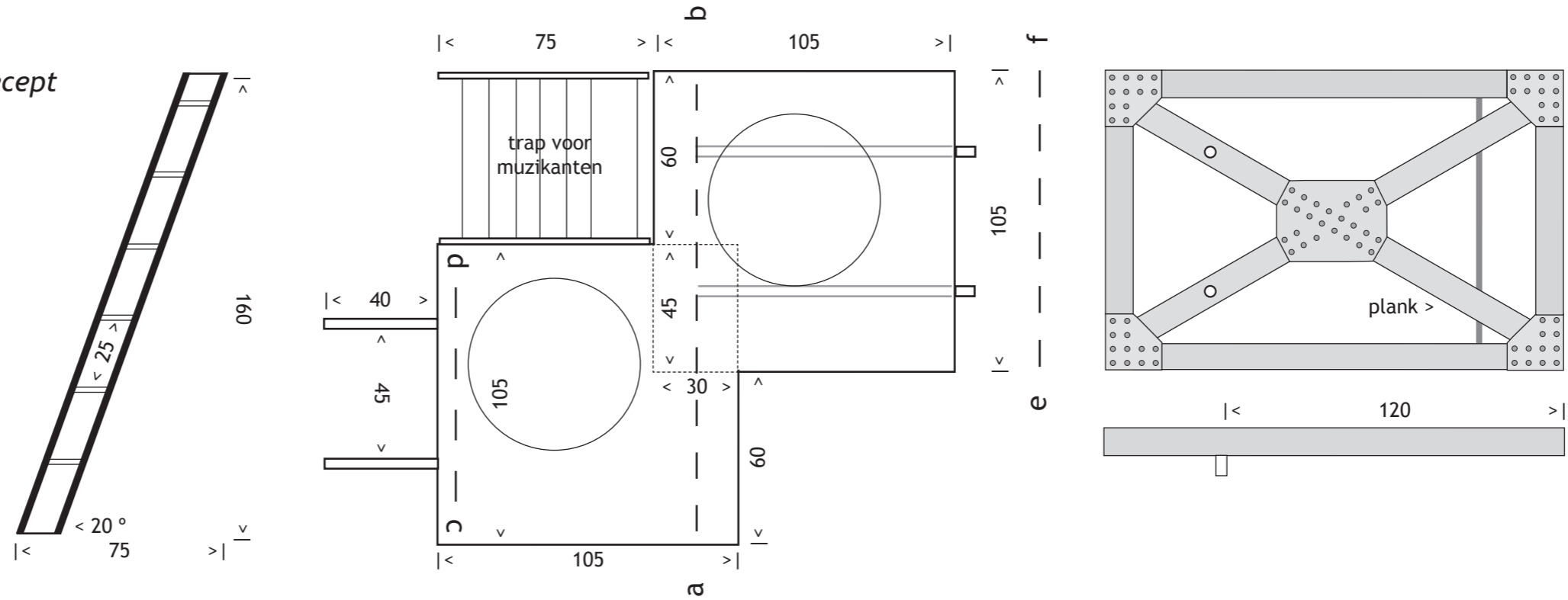

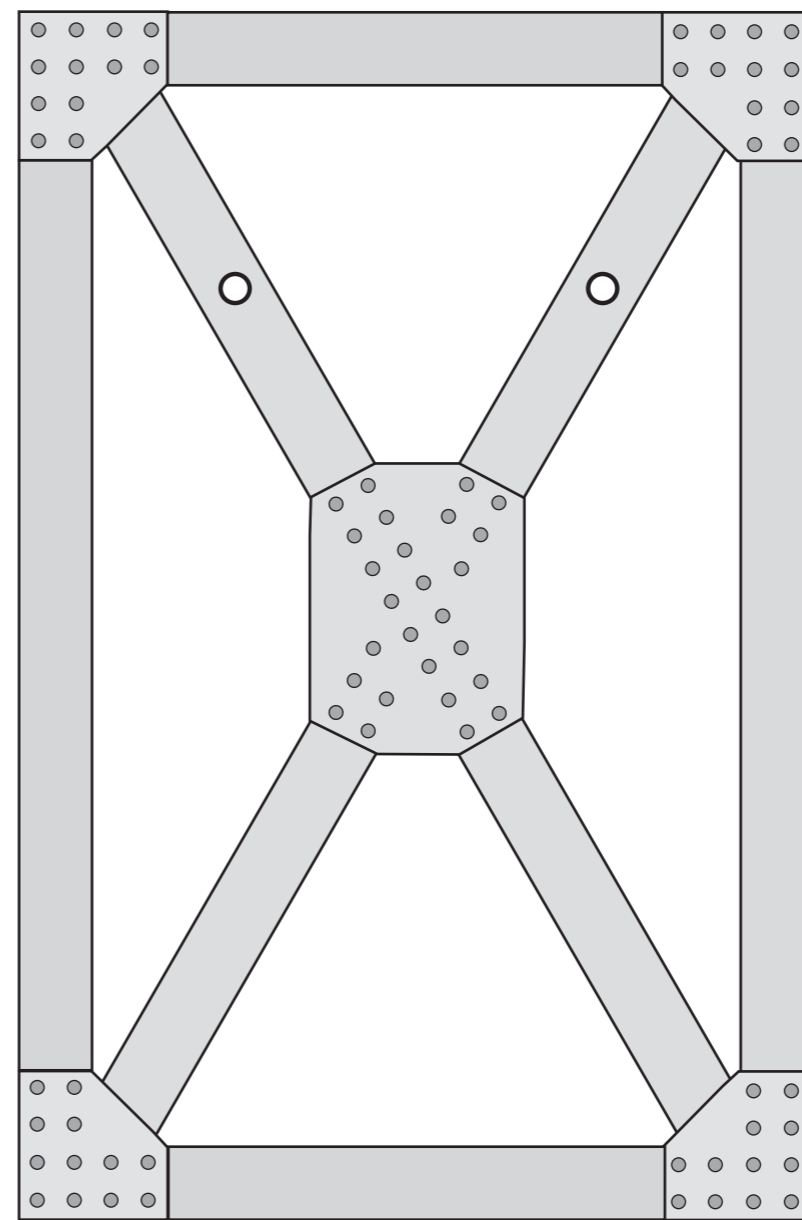
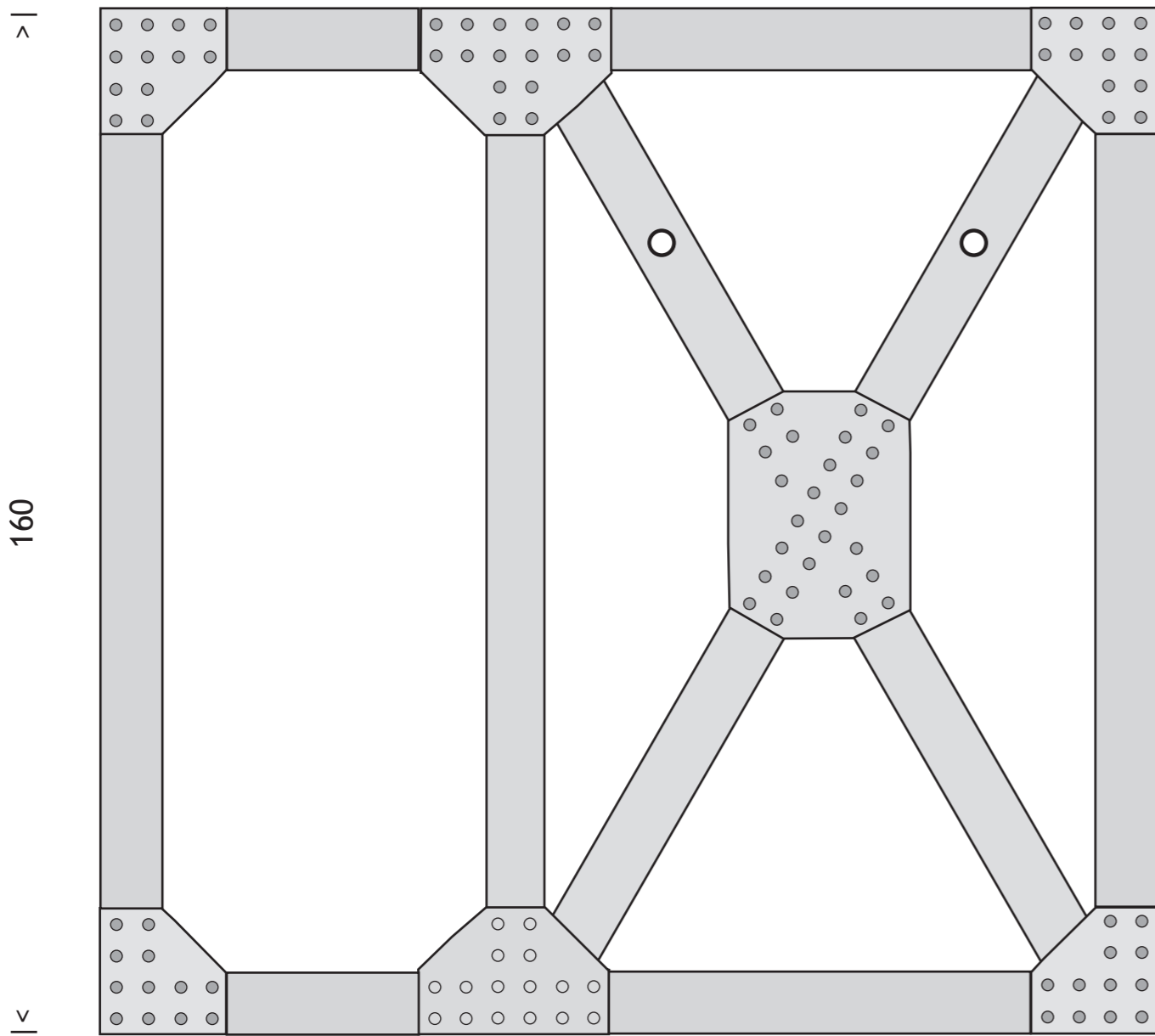

Rossini's Geheime Recept  
 PODIUMDEEL I  
 << details onderbouw  
 hoogte: 160 cm.

Arnold Schalks  
 decorontwerp  
 versie 19 juni 2011  
 schaal 1:10

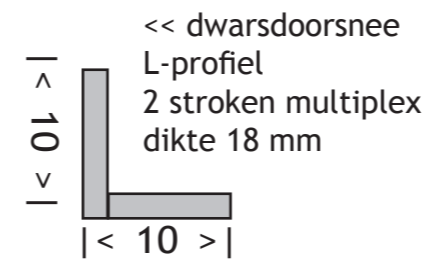
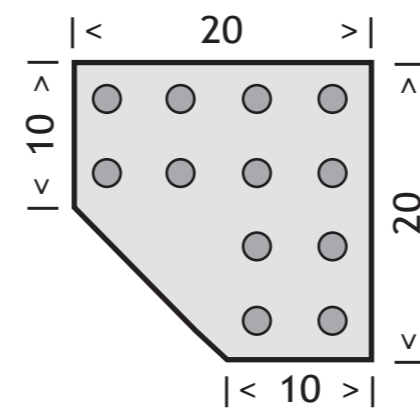
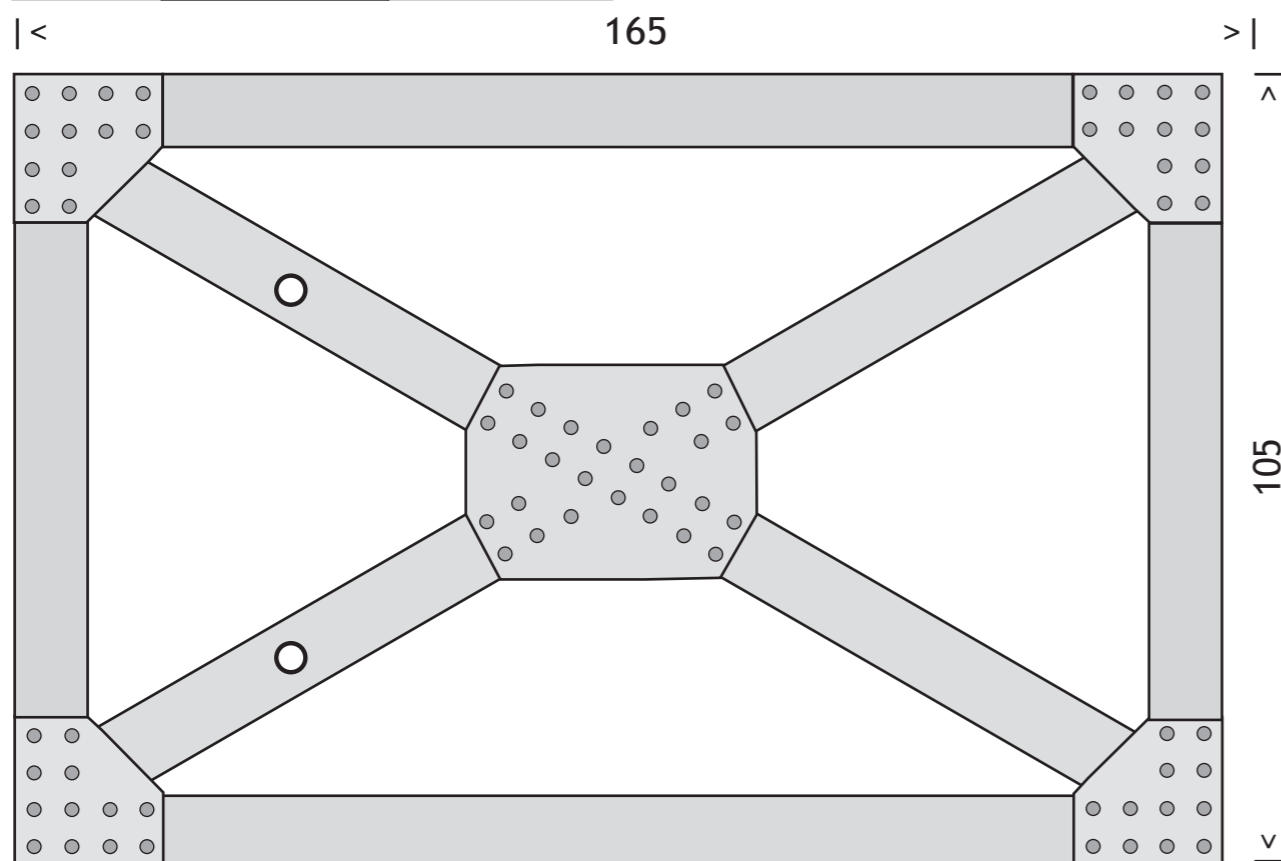

<< dwarsdoorsnee  
 L-profiel  
 2 stroken multiplex  
 dikte 18 mm

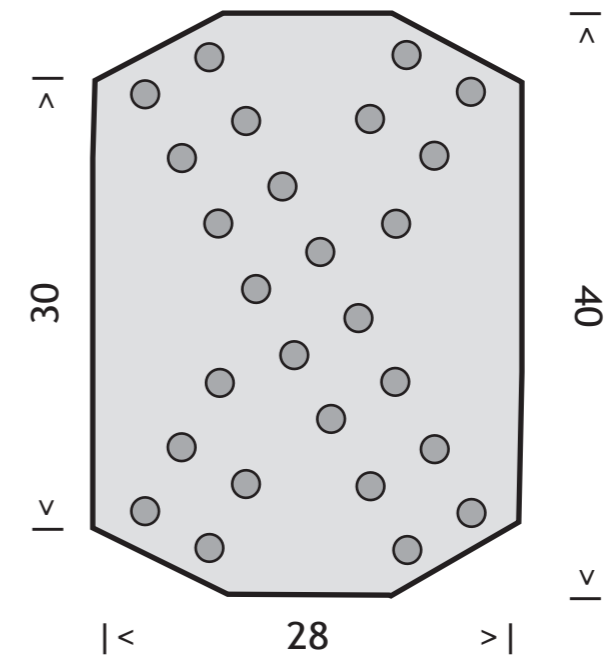

details 'schetsplaten'  
 multiplex / dikte 18 mm  
 schaal 1 : 5 / Ø 'klinknagels': 2 cm.

*Rossini's Geheime Recept*  
PODIUMDELEN I & II  
details vloeren  
hoogte: 160/80 cm.

Arnold Schalks  
decorontwerp  
versie 19 juni 2011  
schaal 1:10

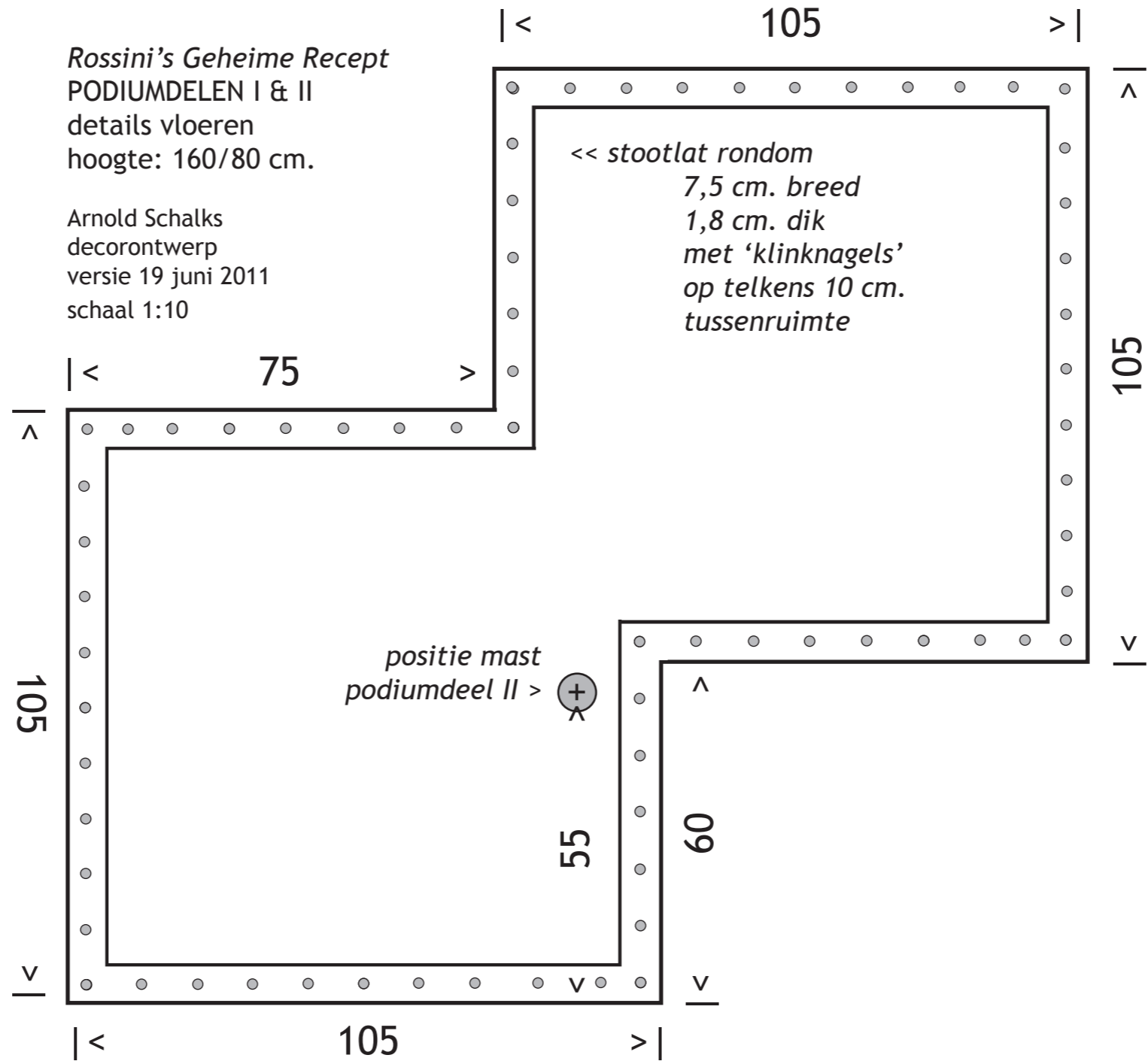

370

< mast Ø 7 cm

*Rossini's Geheime Recept*  
**PODIUMDEEL II**  
overzicht  
onderbouw en vloer  
hoogte: 80 cm.  
plaats voor 2 x klarinet

Arnold Schalks  
decorontwerp  
versie 19 juni 2011  
schaal 1:20

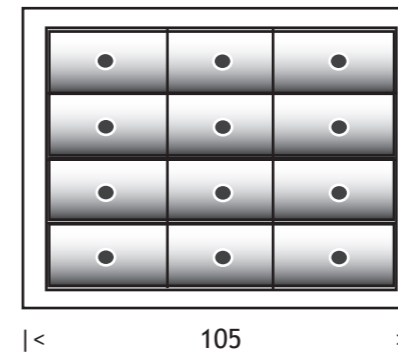
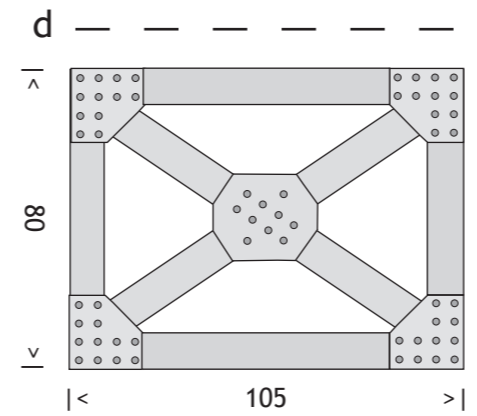
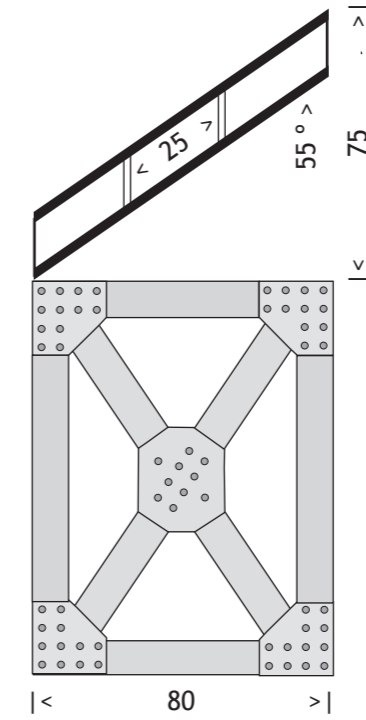
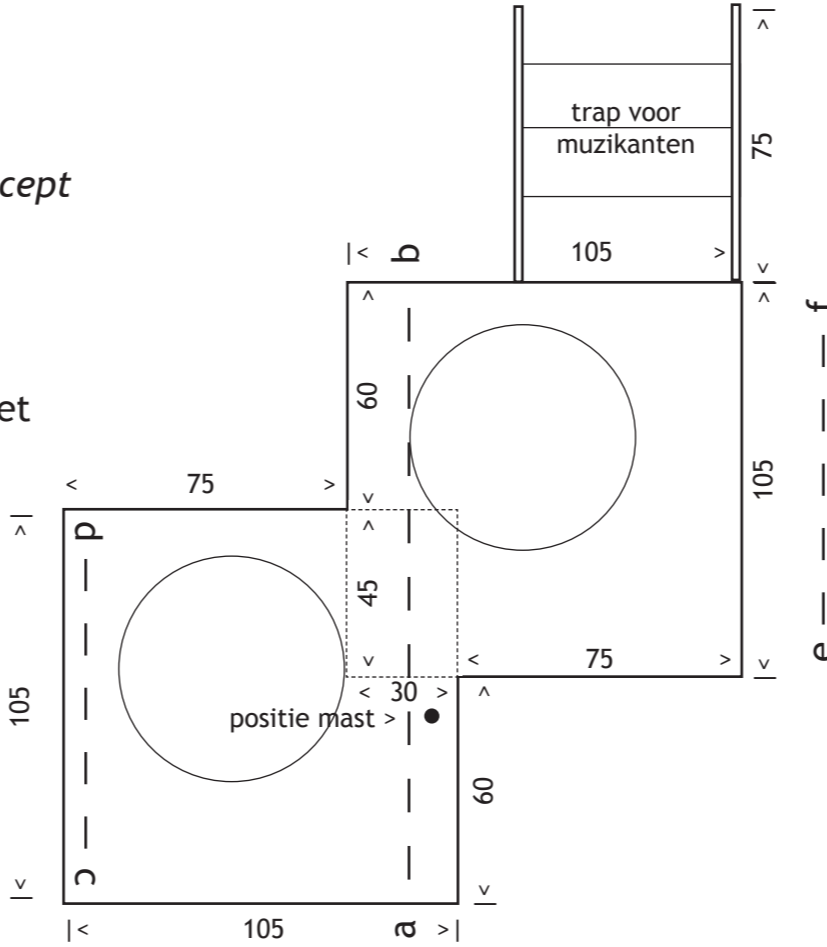
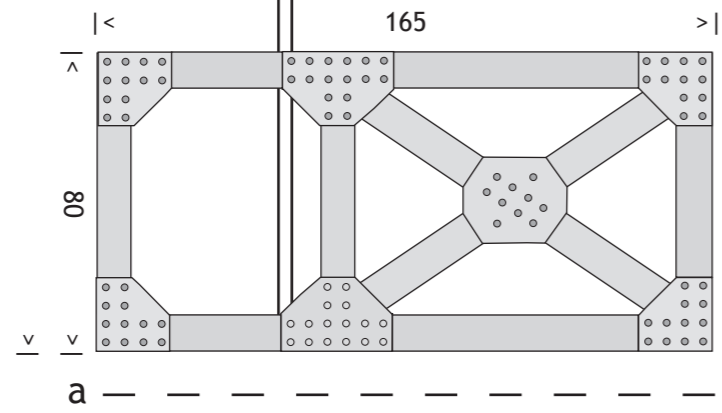

front links:  
ladenkast

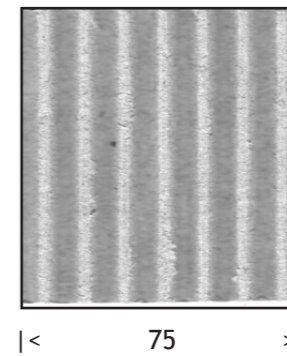

front rechts:  
gordijn

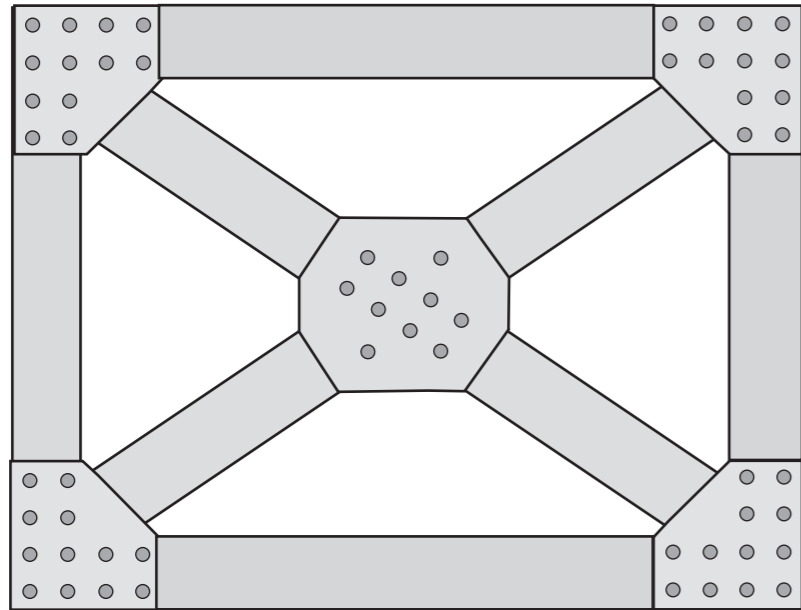

|< 105 >|

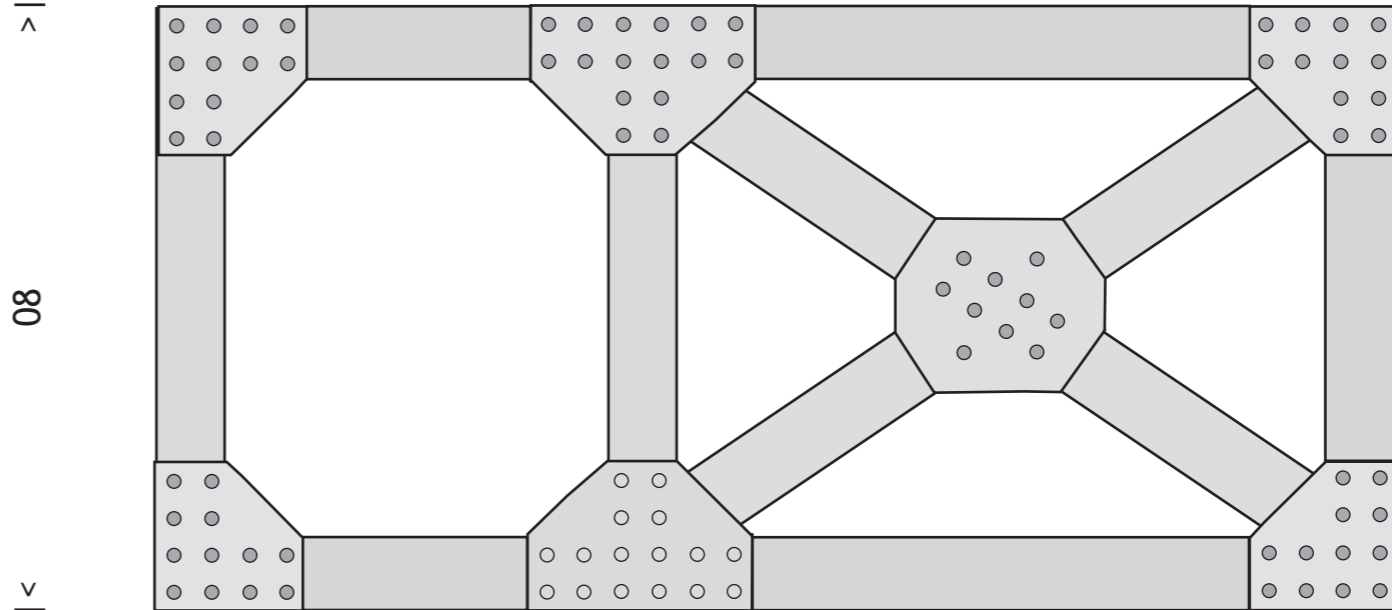

|> 80 <|

|< 165 >|

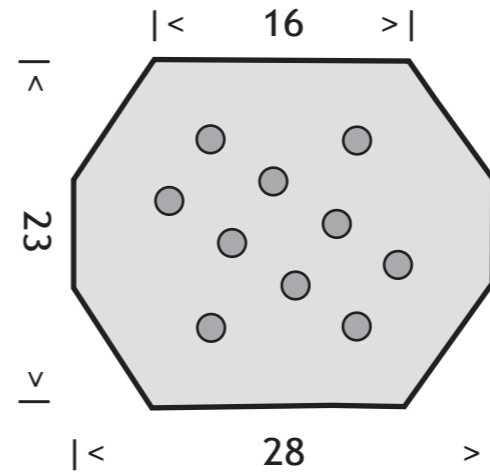
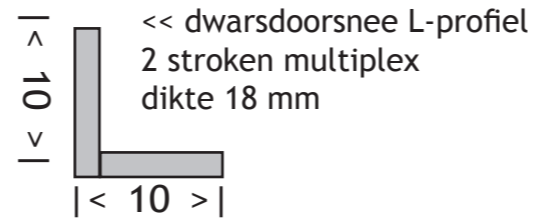
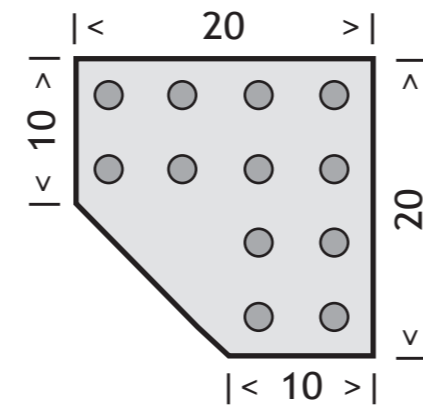
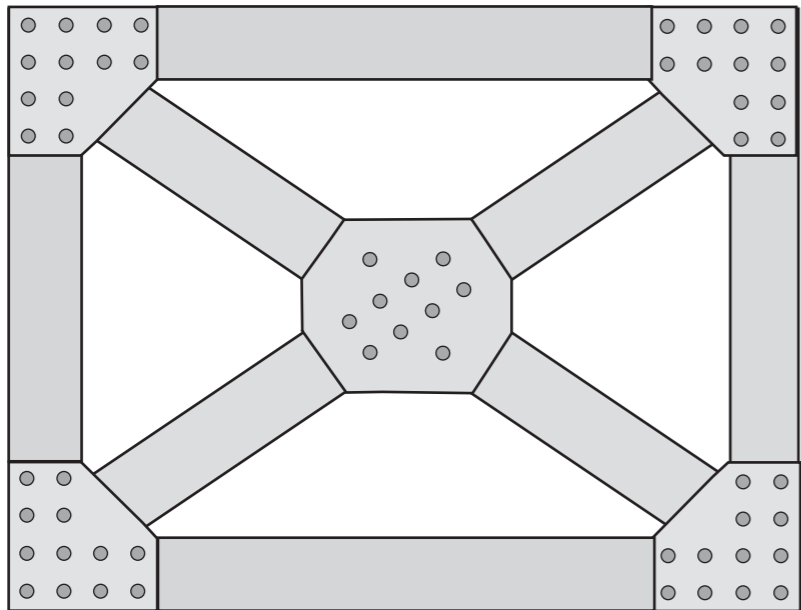

<< detail 'schetsplaten'  
multiplex / dikte 18 mm  
schaal 1 : 5  
Ø 'klinknagels': 2 cm.

*Rossini's Geheime Recept*  
PODIUMDEEL II  
details onderbouw  
hoogte: 80 cm.

Arnold Schalks  
decorontwerp  
versie 19 juni 2011  
schaal 1:20

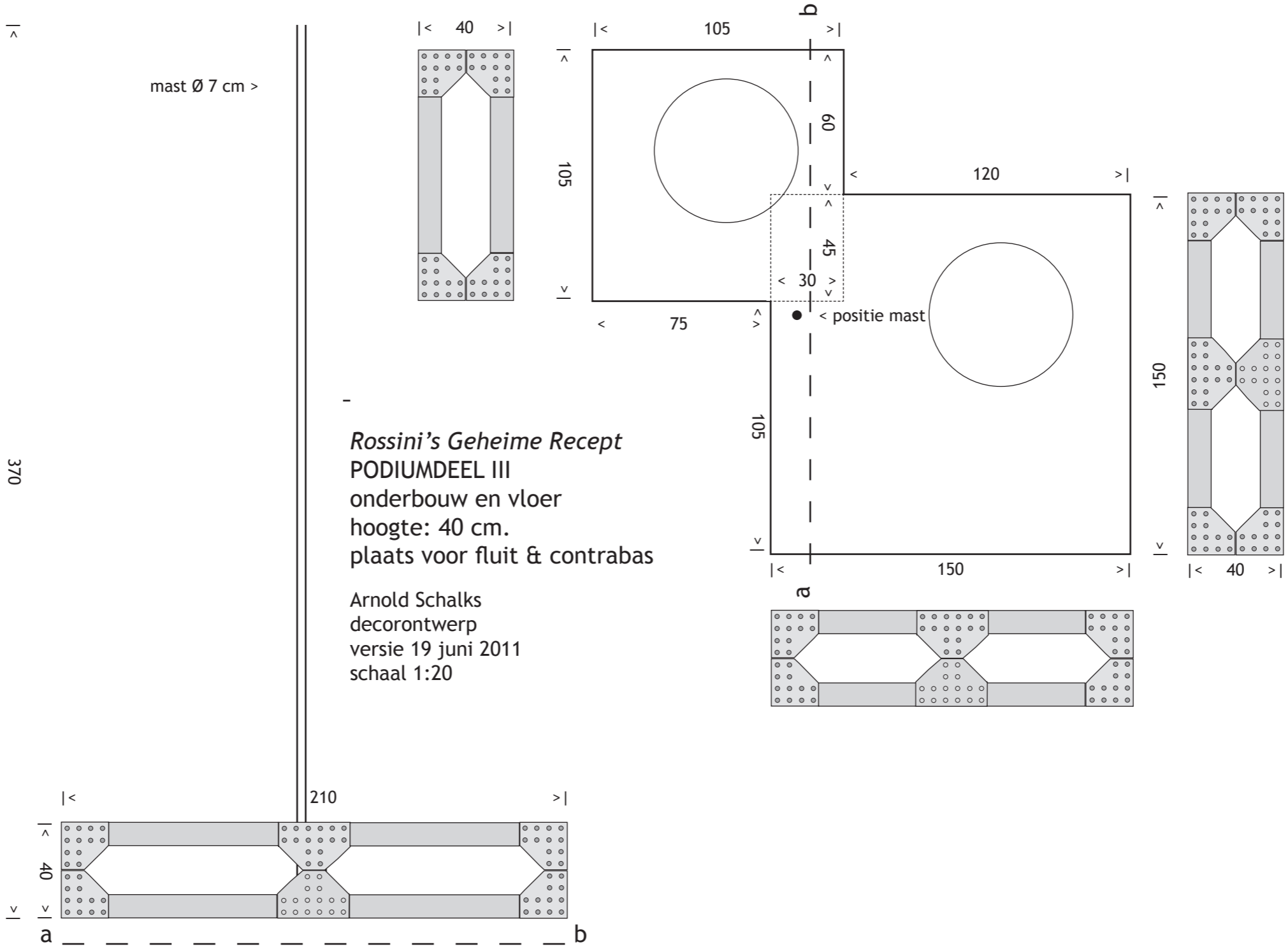

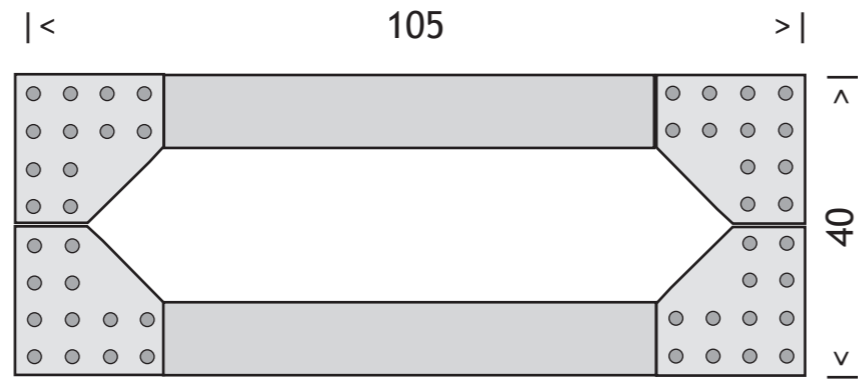

*Rossini's Geheime Recept*  
 PODIUMDEEL III  
 details onderbouw  
 hoogte: 40 cm.

Arnold Schalks  
 decorontwerp  
 versie 19 juni 2011  
 schaal 1:10

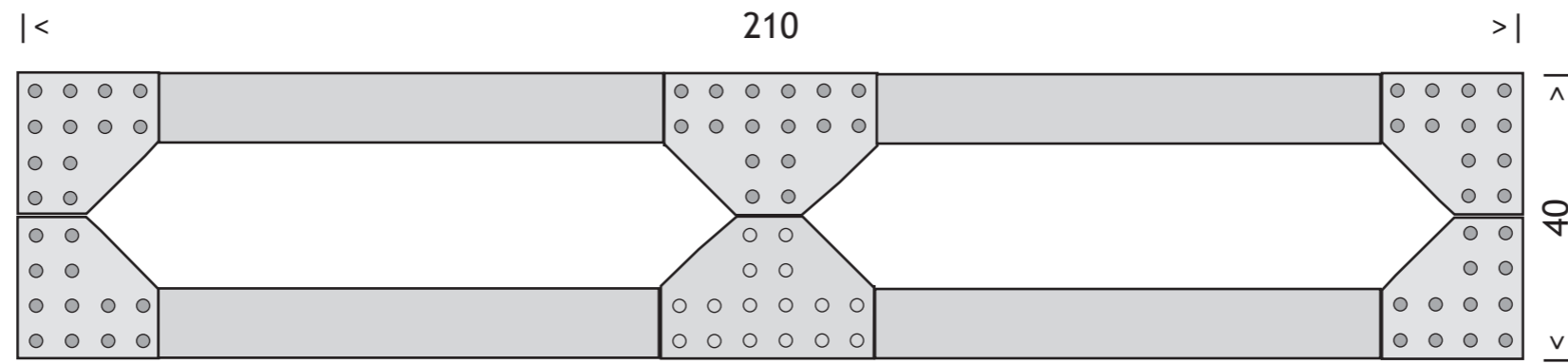
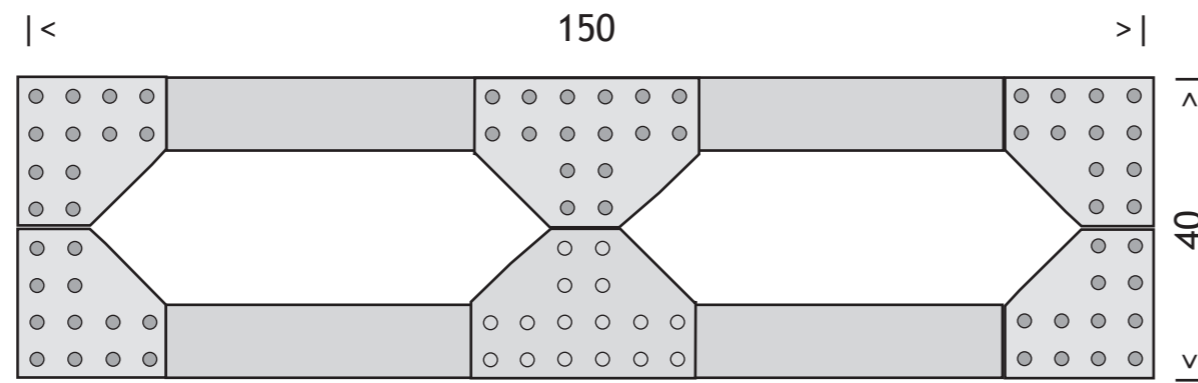
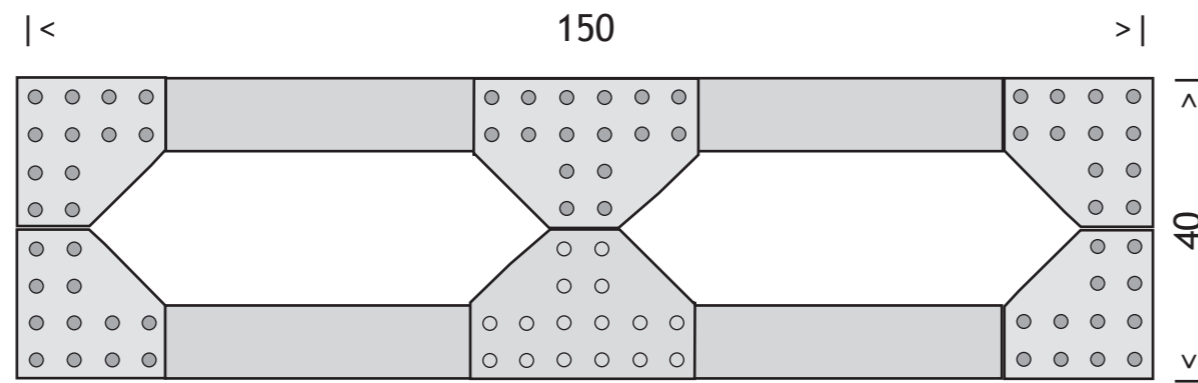

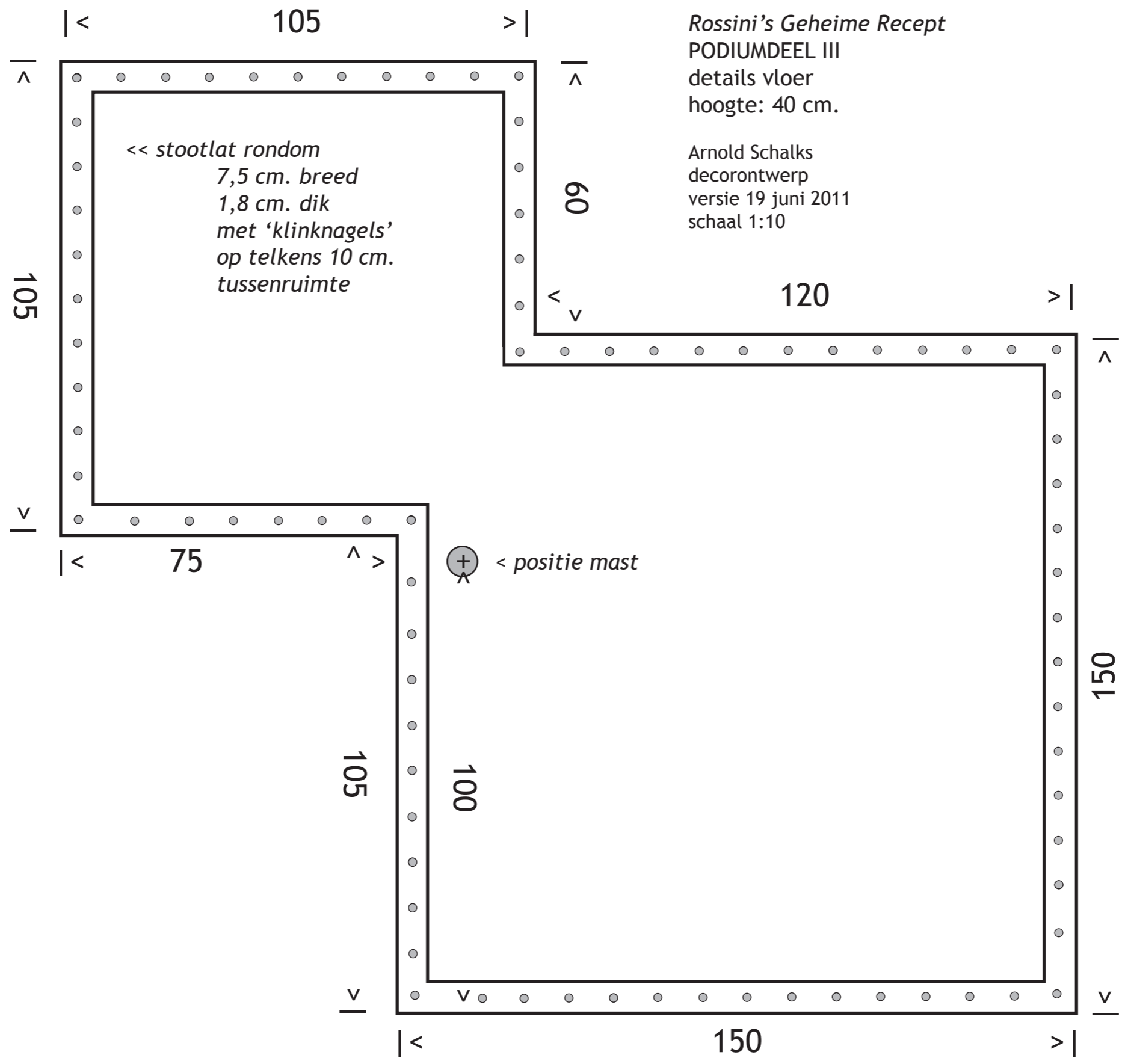

Rossini's Geheime Recept

PODIUMDEEL III

details vloer  
hoogte: 40 cm.

Arnold Schalks  
decorontwerp  
versie 19 juni 2011  
schaal 1:10

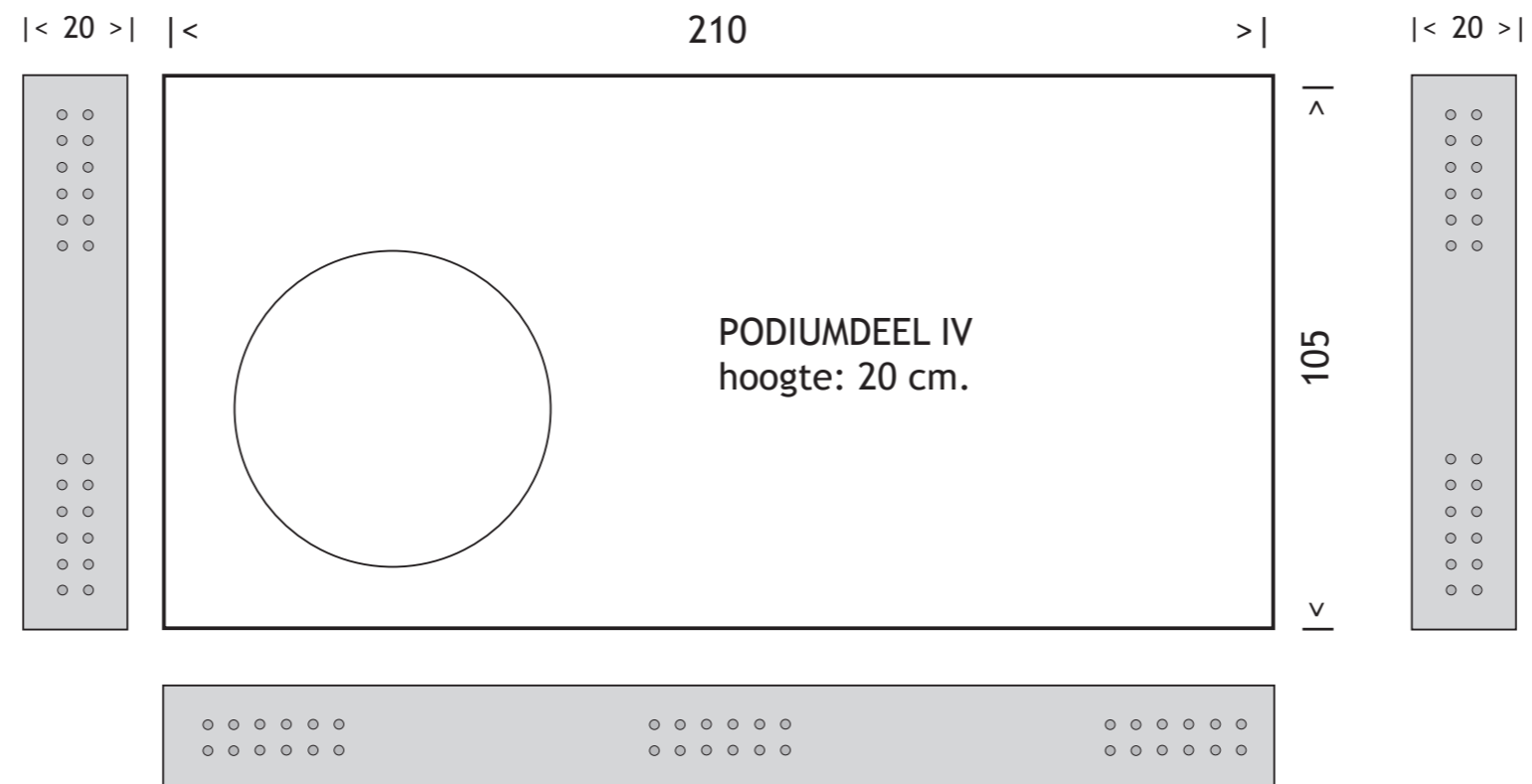

*Rossini's Geheime Recept*  
 PODIUMDEEL IV  
 overzicht onderbouw en vloer  
 hoogte: 20 cm.  
 plaats voor fagot

Arnold Schalks  
 decorontwerp  
 versie 19 juni



fauteuil voor Rossini

Rossini's Geheime Recept  
 PODIUMDEEL IV  
 details vloer & onderbouw  
 hoogte: 20 cm.

Arnold Schalks  
 decorontwerp  
 versie 19 juni 2011  
 schaal 1:10

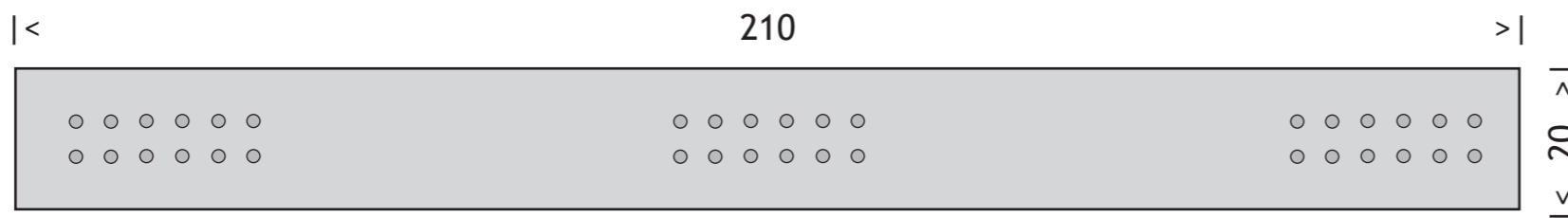
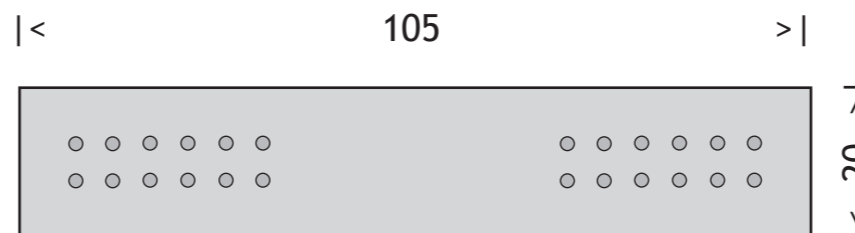
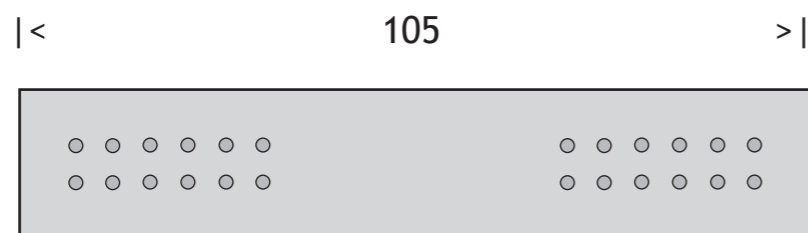
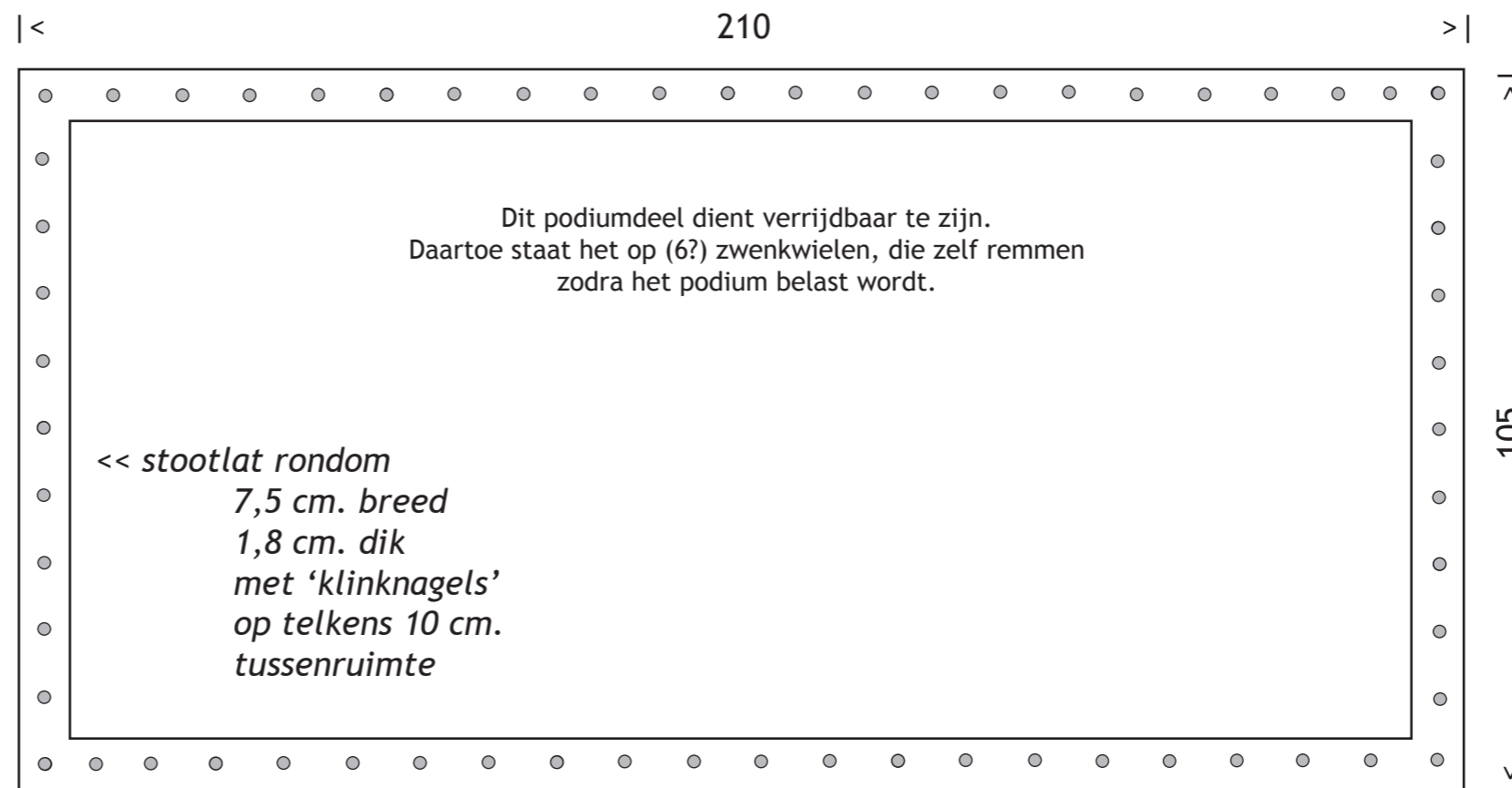

<< frontjes onderbouw  
 multiplex  
 dikte 18 mm  
 schaal 1 : 5  
 Ø 'klinknagels': 2 cm.

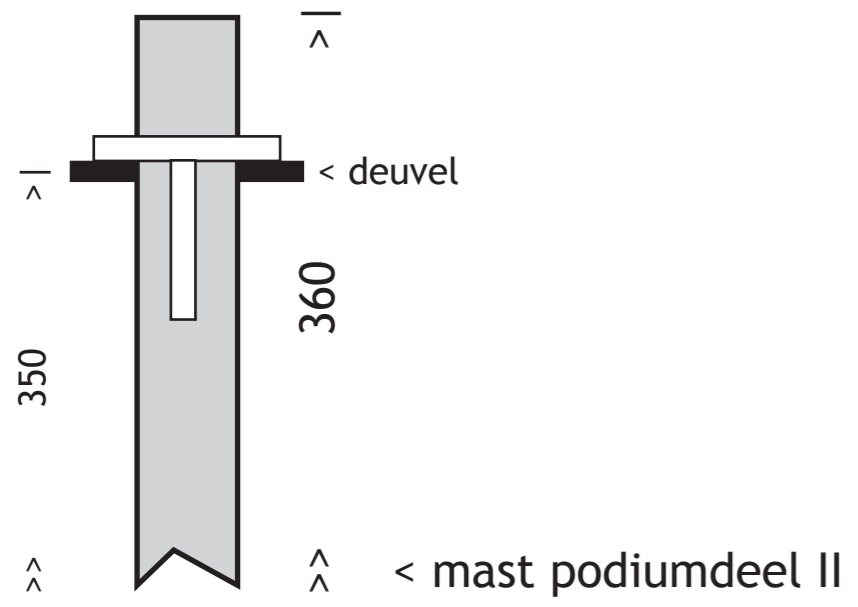
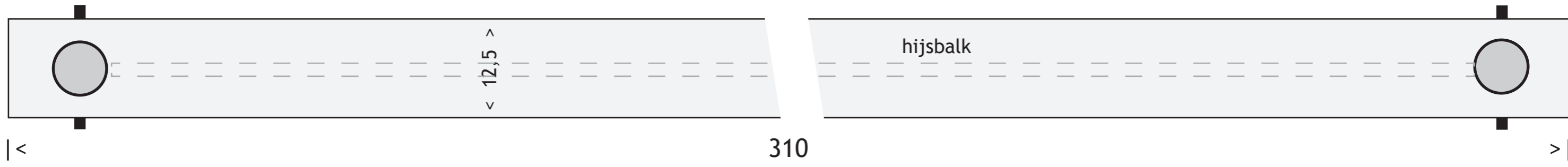
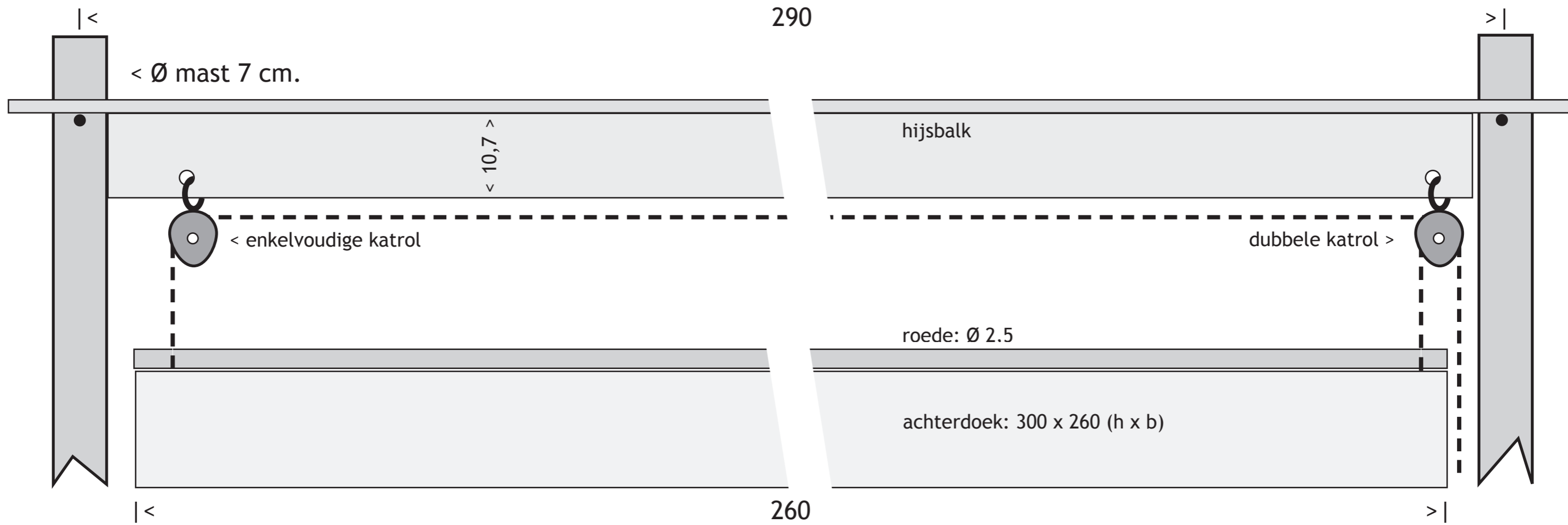

Rossini's Geheime Recept  
 ACHTERDOEK  
 details masten en takelage

Arnold Schalks  
 decorontwerp  
 versie 19 juni 2011

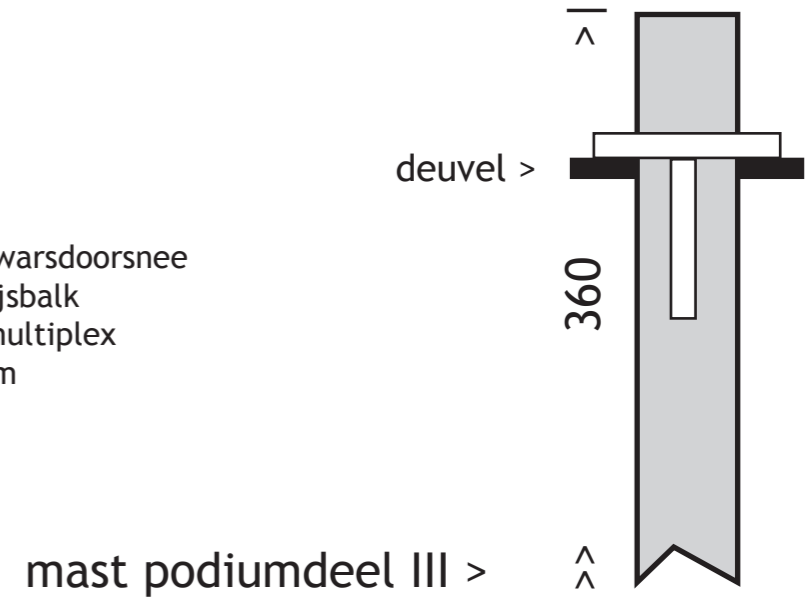
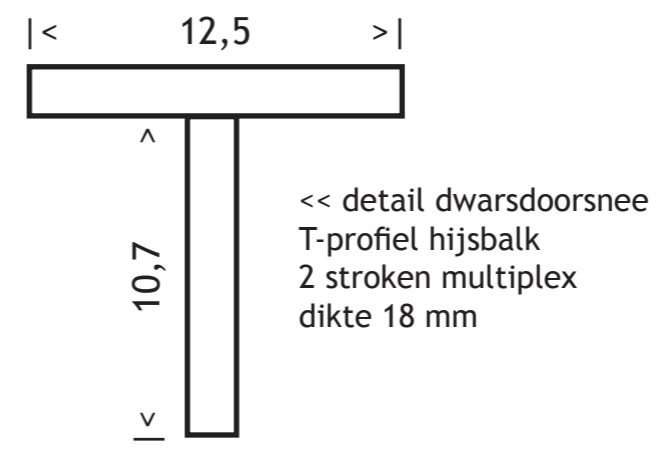

*Rossini's Geheime Recept*  
ruimtebeslag vloerdelen  
podium in verticale positie  
voor transport camionette

Arnold Schalks  
versie 19 juni 2011

<b>maten camionette</b>
hoogte max: 2 m
breedte max: 2,1 m
lengte max: 4,5 m

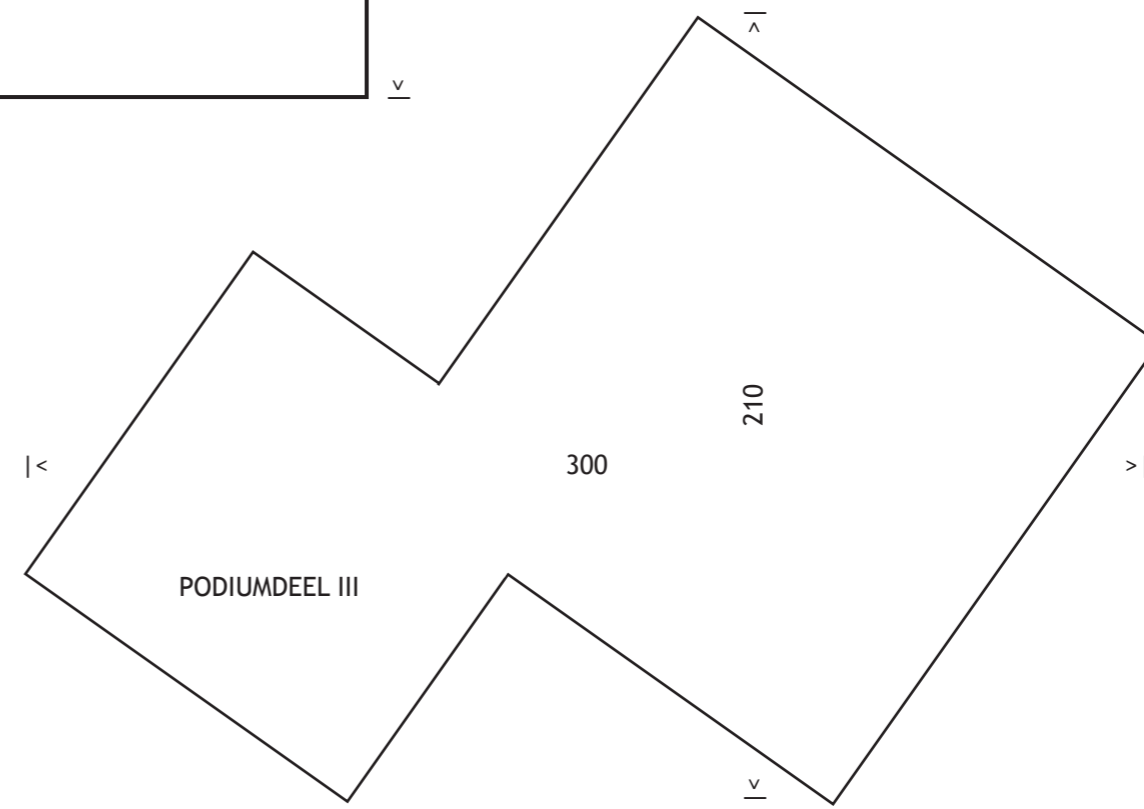
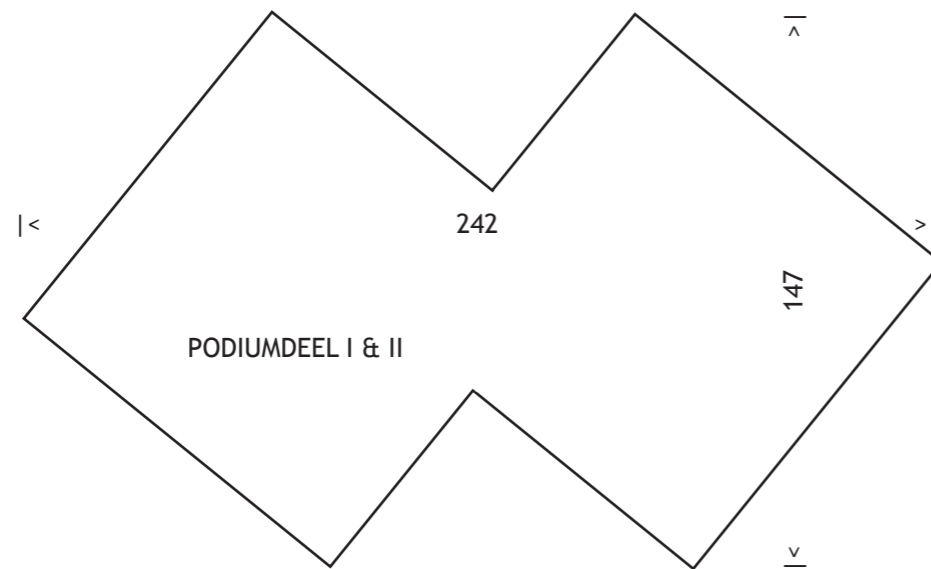
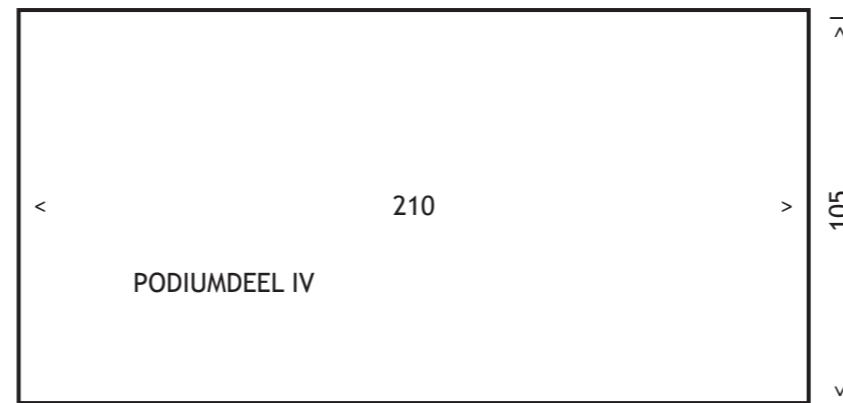



Voor de bezetting/bezitting van de podia zijn voor de blazers van bovenstaande stoelen elk twee exemplaren aangeschaft.